

DH200F

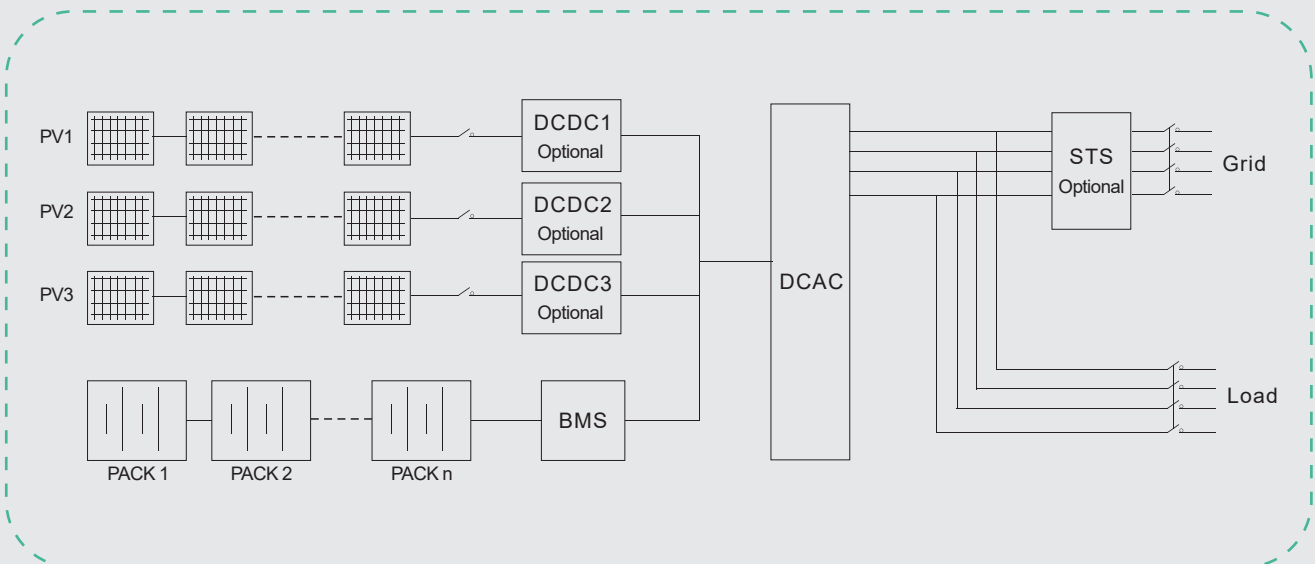

All-in-one integrated system design inside the Cabinet to fulfill C&I scenarios.

- Overall solar+ storage solution
- All-in-one design concept
- High-level safety design
- Convenient outdoor setup
- Allow flexible system design
- Capacity expandable to megawatts



Technical Specifications

Battery Specifications

Battery Module Type	HV51280F
Cell Capacity	280Ah
Battery Voltage Range	672~864V
Nominal Current	140A (0.5C)
System Storage Power	215kWh

AC Specifications (on-grid)

Nominal Power	100kW
AC Nominal Voltage	400V
Wiring	3P4L+PE
Nominal Frequency	50Hz
AC Maximum Current	158A
Max.number of BESS in parallel	12

AC Specifications (off-grid)

Nominal Power	100kW
AC Nominal Voltage	400V
Wiring	3P4L+PE
Nominal Frequency	50Hz
AC Maximum Current	158A
Unbalanced Load Capacity	100%
On-grid Switching to Off-grid Time	< 20ms
Off-grid Switching to On-grid Time	< 20ms
Max.number of BESS in parallel	5

Photovoltaic Input

MPPT Voltage Range	200-670V
MPPT channels	Up to three
Input Power	Single channel 50kW

System Specifications

Dimensions(W*D*H)	1850*1200*2250mm
Weight	≈3300kg
Air Conditioner Power	3kW (Cooling capacity)
Operation Temperature	-20~50°C
Operation Humidity	0~95%(Non-condensing)
Protection Level	IP55
Anti-corrosion Level	C3
Noise Level	≤75dB
Altitude	≤3000m
Cooling System	Fan Cooling
Display	Touch screen (optional)
Firefighting	Aerosol/Heptafluoropropane (FM-200)/Perfluoro
EMS Communication	Ethernet
Certification	CE/CQC

