



SMART ENERGY/GREEN BUILDING SYSTEM INTEGRATOR

SENTA ENERGY

Senta Energy is located in Wuxi, the largest solar Power industry base in China. Senta Energy is a hightech enterprise mainly engaged in Solar power and Energy storage products, New building prefabricated houses and New agricultural distributed planting business.

Storage company: Sendo ESS

Energy storage, Battery pack, Portable power supply, Inverter, System integration, etc



Contact Us

Website: www.sentaenergy.com/www.sendoess.com

Telephone: +86 510 8359 2969

Mailbox: sales@sentaenergy.com

Address: RM.501,Bld.1,No.33 Zhihui Road,Huishan District,Wuxi,Jiangsu,China



BATTERY STORAGE SERIES

STORE ENERGY STORE FUTURE

- WALL MOUNTED BATTERY
- STACK MOUNTED BATTERY
- MOVABLE AIO MACHINE

■ LFP 5-10kWh/LV



LFP 5-10KWH / LV

51.2V 100/200Ah

LiFePO4 BATTERY

- High inverter compatibility
- Natural cooling system
- >15Years life span
- Reliable LFP cells
- Scalable up to 160kWh (16Parallel)
- Cells cycle times 6000 cycles
- CANbus standard connection
- IP65 Rating Triple hardware protection
- Smart BMS system to optimize the performance



Specifications

Electrical Characteristics

Model	LFP 5kWh/LV	LFP 10kWh/LV
Available Energy	4.6kWh	9.2kWh
Nominal Discharge/Charging power	2.5kW	5kW
Peak Power (Discharge Only)	2.9kWh for 3 seconds	5.8kWh for 3 seconds
Constant Current (Discharge Only)	50A	100A
Voltage Range	48-56Vd.c	
Nominal Voltage	51.2Vd.c	
Max. Charge Voltage	59.2V±0.5Vd.c	
Weight	65kg	116.5kg
Dimension(mm)	490(550)*650(700)*196(216)mm	585(645)*940(995)*205(225)mm
Certificates	CE, UN38.3, IEC62619, IEC63056	

Max.recommended DOD	90%
Operating Condition	indoor or outdoor
Operating Temperature	Charge 0~45°C
	Discharge -10~50°C
Humidity	4~100% (No condensed water)
Pollution Degree	3
Over Voltage Category	II
Cooling Type	Natural cooling
Case Material	Metal+Plastic
IP rating	IP 65
Protective Class	I
Max.Number of Parallel or Series	16
Warranty	10 years
Life Span	>15 years
Communication	CAN/RS485
Protection Mode	Triple hardware protection
Battery Protection	Over-current/Over-voltage/Short circuit/Under-voltage
Hazardous Material Classification	9

Compatible Inverters

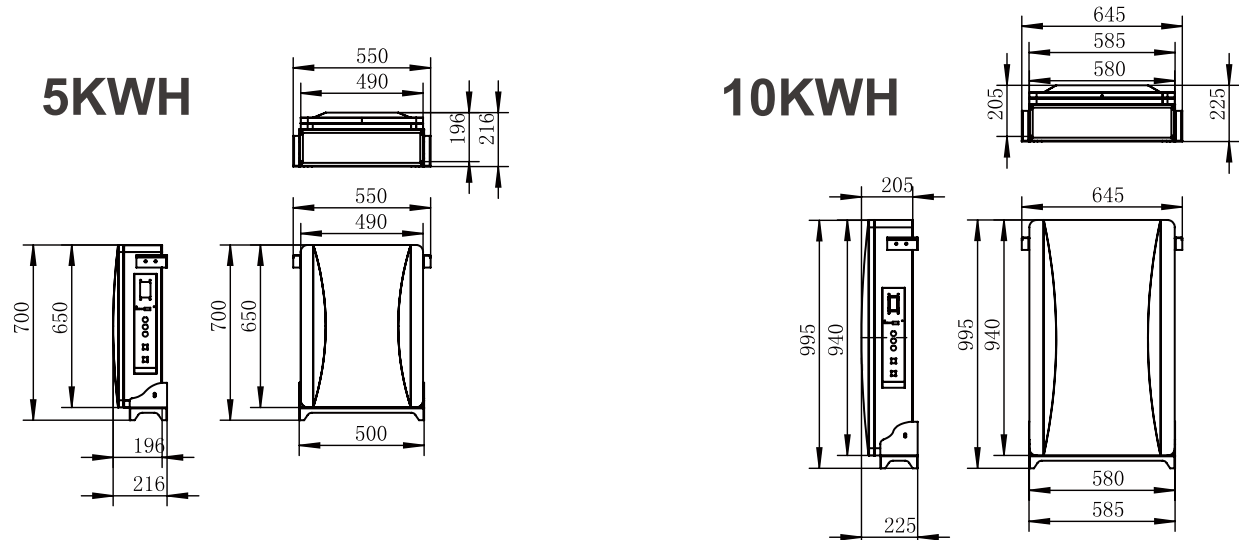

■ LFP 9-30kWh/HV



LFP 3000 / HV
57.6V 50Ah Each block
 LiFePO4 BATTERY

- High inverter compatibility
- Home Automation
- >15Years life span
- Reliable LFP cells
- Wi-Fi Communication
- Cells cycle times 6000 cycles
- CANbus standard connection
- IP54 Rating Triple hardware protection
- Smart BMS system to optimize the performance



Specifications

Electrical Characteristics

Model	LFP 9kWh	LFP 12kWh	LFP 15kWh	LFP 18kWh	LFP 21kWh	LFP 24kWh	LFP 27kWh	LFP 30kWh
Available Energy*	8.64kWh	11.52kWh	14.40kWh	17.28kWh	20.16kWh	23.04kWh	25.92kWh	28.80kWh
Battery Module	LFP 3000/HV:57.6V 50Ah							
Number of Modules	3	4	5	6	7	8	9	10
Nominal Voltage	172.8V	230.4V	288V	345.6V	403.2V	460.6V	518.4V	576V
Operating Voltage Range	135-197.1V	180-262.8V	225-328.5V	270-394.2V	315-459.9V	360-525.6V	405-591.3V	450-657V
Nominal Discharge/Charging Current	50/25A							
Max.Charge Voltage	197.1V	262.8V	328.5V	394.2V	459.9V	525.6V	591.3V	657V
Weight	102kg	131kg	160kg	189kg	218kg	247kg	276kg	305kg
Dimension(mm)	670*330*697	670*330*855	670*330*1013	670*330*1171	670*330*1329	670*330*1487	670*330*1645	670*330*1803
Certificates	CE,UN38.3,IEC62619,IEC63056							

Max.recommended DOD	90%
Operating Condition	indoor or outdoor
Operating Temperature	Charge 0~55°C Discharge -20~55°C
Humidity	0~95% (No condensed water)
Pollution Degree	3
Over Voltage Category	II
Cooling Type	Natural cooling
Case Material	Metal+Plastic
IP Rating	IP 54
Protective Class	I
Warranty	10 years
Life Span	>15 years
Communication	CAN/WIFI
Protection Mode	Triple hardware protection
Battery Protection	Over-current/Over-voltage/Short circuit/Under-voltage
Hazardous Material Classification	9

Compatible Inverters

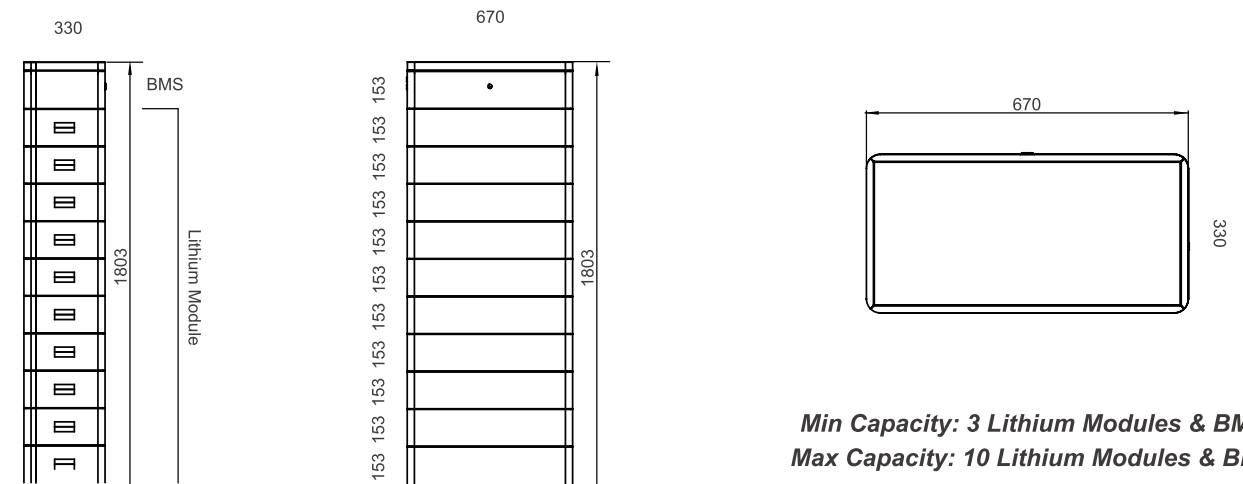

Min Capacity: 3 Lithium Modules & BMS
 Max Capacity: 10 Lithium Modules & BMS

■ SNE 1000-2.56/2000-5.12/3000-10.24



- LiFePO4 Safe Battery Chemistry
- Plug and Play
- MPPT and Pure Sine Wave Inverter
- Multiple Working Modes
- Intelligent Protection for Safety Use
- AC Charge and UPS Function



Specifications

Electrical Characteristics

Model	SNE 1000-2.56	SNE 2000-5.12	SNE 3000-10.24
Rated AC Output Power	1.5KW	3KW	5KW
Peak Power (20ms)	4.5KW	9KW	15KW
AC Output Voltage	100-120V/220-240V		
Output Frequency	50/60Hz		
Output Waveform	Pure Sine Wave		
USB Output	5V 2A		
Max AC Charge Current	40A		
Max PV Input Power	1040W	2080W	3120w
Max PV Input Voltage	150V		
MPPT Charging Current	24V 40A	48V 40A	48V 60A
Battery Type	LiFePO4		
Battery Capacity	2.56KWh	5.12KWh	10.24KWh
Nominal Voltage	25.6V	51.2V	51.2V
Operating Voltage	22.4 – 29.2V	44.8 – 58.5V	44.8 – 58.5V
Cycles Life	> 6,000		
Communication	RS485		
Cooling Type	Fan Cooling		
Working Temperature	-20 – 55°C		
Protection	Short Circuit, Over Charge/Discharge, Over Current/Temp		
Enclosure Protection Rating	IP40		
Dimension (W*H*D, mm)	592*820*260	592*820*260	642*1129*280
Weight	60kg	90Kg	140kg
Warranty	3 Years		
Certificates	CE ,TUV,IEC, RoHs		

Connection Diagram

